

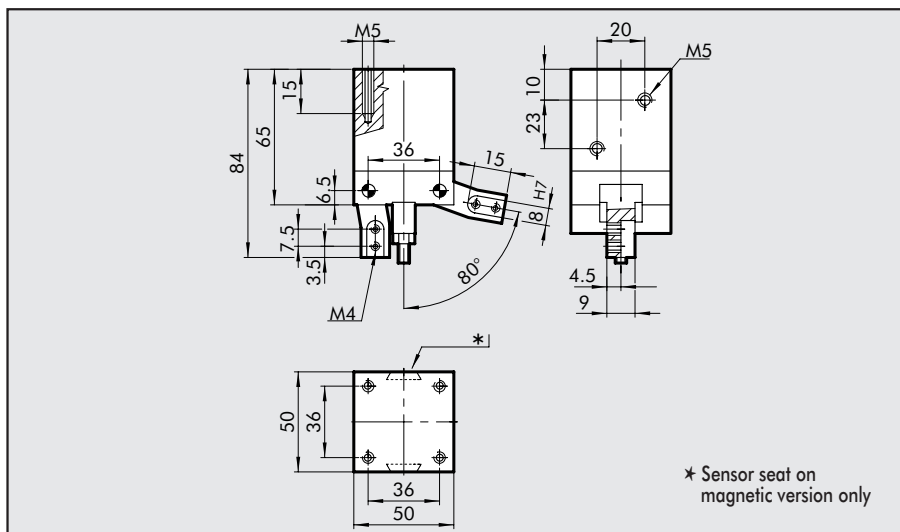



### DIMENSIONS OF GRIPPERS P9-32



### ORDERING CODES

| Code        | Description                    |
|-------------|--------------------------------|
| W1520320160 | HINGED GRIPPER GR-032-HVY      |
| W1530320160 | HINGED GRIPPER GR-032-HVY-MAGN |

1

### ACCESSORIES: MAGNETIC SENSORS

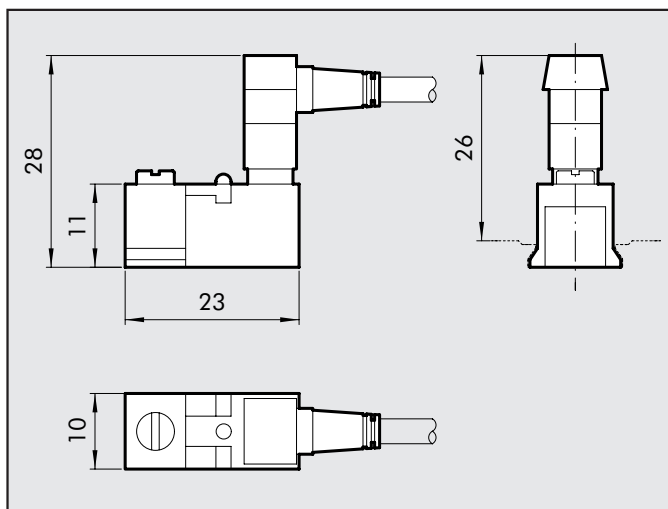

### ORDERING CODES

| Code        | Description                       | Sigla                     |
|-------------|-----------------------------------|---------------------------|
| W0950000252 | Reed connector + bracket - CB     | REED SENSOR DCB 2C-425    |
| W0950000253 | Hall PNP connector + bracket - CB | HALL PNP SENSOR DCB3-N225 |

N.B.: For technical features of sensors, see Accessories for SSCV cylinders page 1.1/32

### NOTES