

DIMENSIONS OF GRIPPERS SERIES P7 - 20

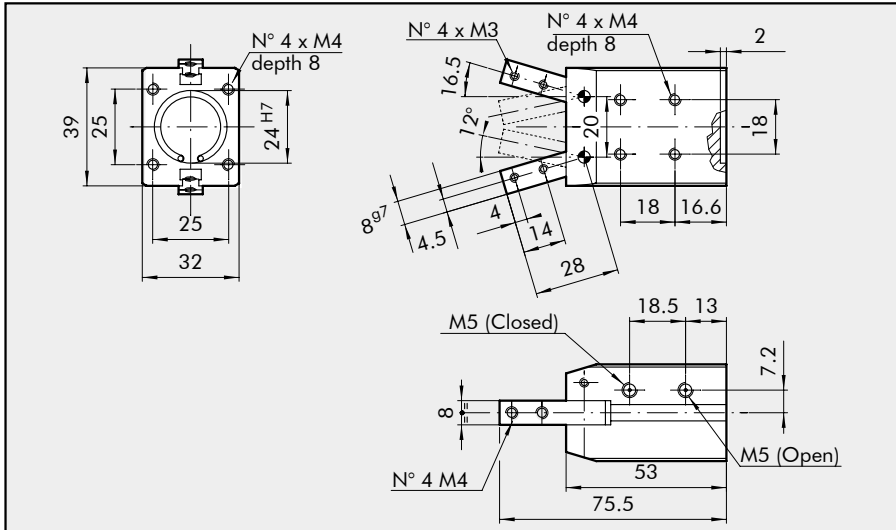

ORDERING CODES

Code	Description
W1590200200	GRIPPER WITH 2 HINGED JAWS P7-20

DIMENSIONS OF GRIPPERS SERIES P7 - 32

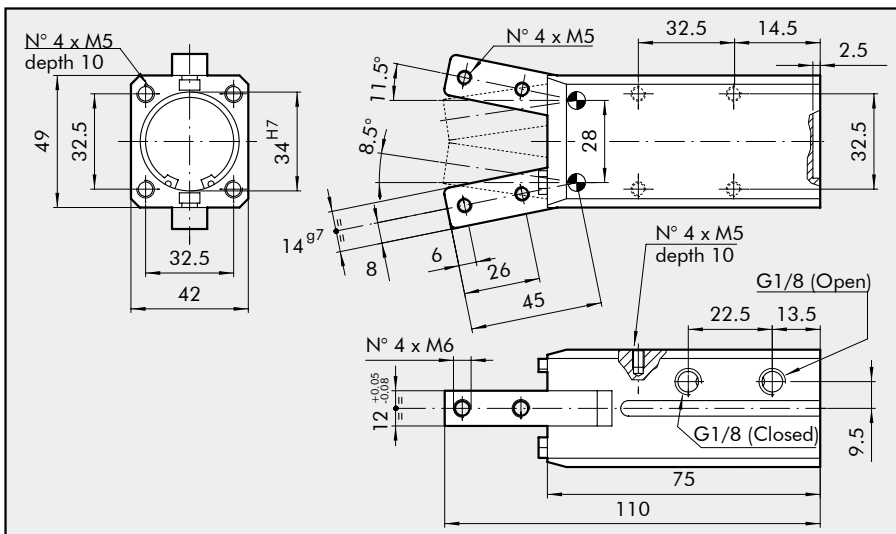

ORDERING CODES

Code	Description
W1590320200	GRIPPER WITH 2 HINGED JAWS P7-32

DIMENSIONS OF GRIPPERS SERIES P7 - 50

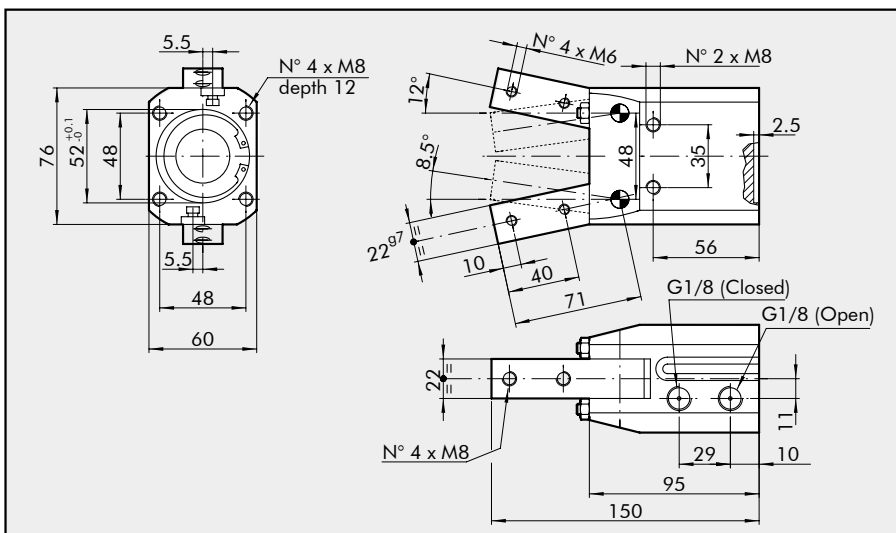

ORDERING CODES

Code	Description
W1590500200	GRIPPER WITH 2 HINGED JAWS P7-50

RETRACTING SENSOR

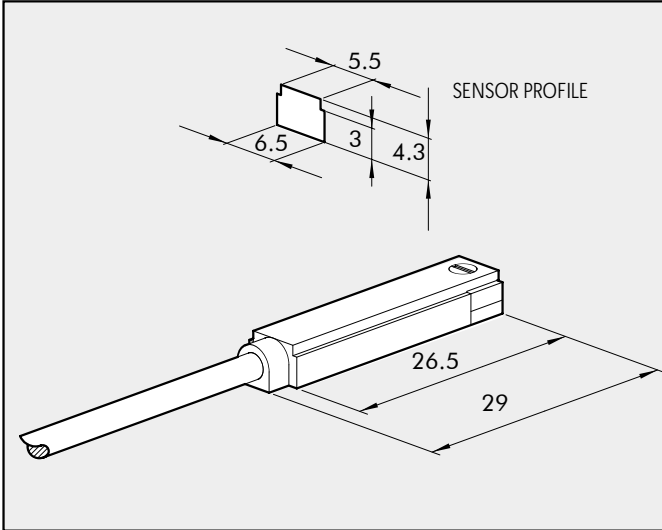

Code	Description
W0950025390	Hall sensor DSL, 3 wires, NO 2.5 m
W0950029394	Hall sensor DSL, 3 wires, NO 300 mm M8
W0950022180	Hall sensor DSL, 2 wires, NO 2.5 m
W0950028184	Hall sensor DSL, 2 wires, NO 300 mm M8

NOTE