

GRIPPERS WITH 2 PARALLEL ROLLER-RECIRCULATION JAWS SERIES P2

These are grippers with 2 parallel jaws with a roller-recirculation guiding system. Double-acting system with clamping in both directions. All the grippers come with magnet and sensor slots.



TECHNICAL FEATURES		P2 - 6	P2 - 10	P2 - 16	P2 - 20	P2 - 25
Min./max. operating pressure	bar			1.5 - 7		
Temperature range	°C			5 - 60		
Maximum operating frequency	cycles/s			2		
Size		6	10	16	20	25
Bore	mm	6	12	16	20	25
Single jaw stroke	mm	2	2	3	5	7
Closing force at 6 bar	N	5.3	28	83	97	180
Opening force at 6 bar	N	7.4	35	95	115	210
Weight	Kg	0.027	0.048	0.12	0.24	0.45

DIMENSIONS OF GRIPPER WITH 2 PARALLEL ROLLERS-RECIRCULATION JAWS - SERIES P2 - 6

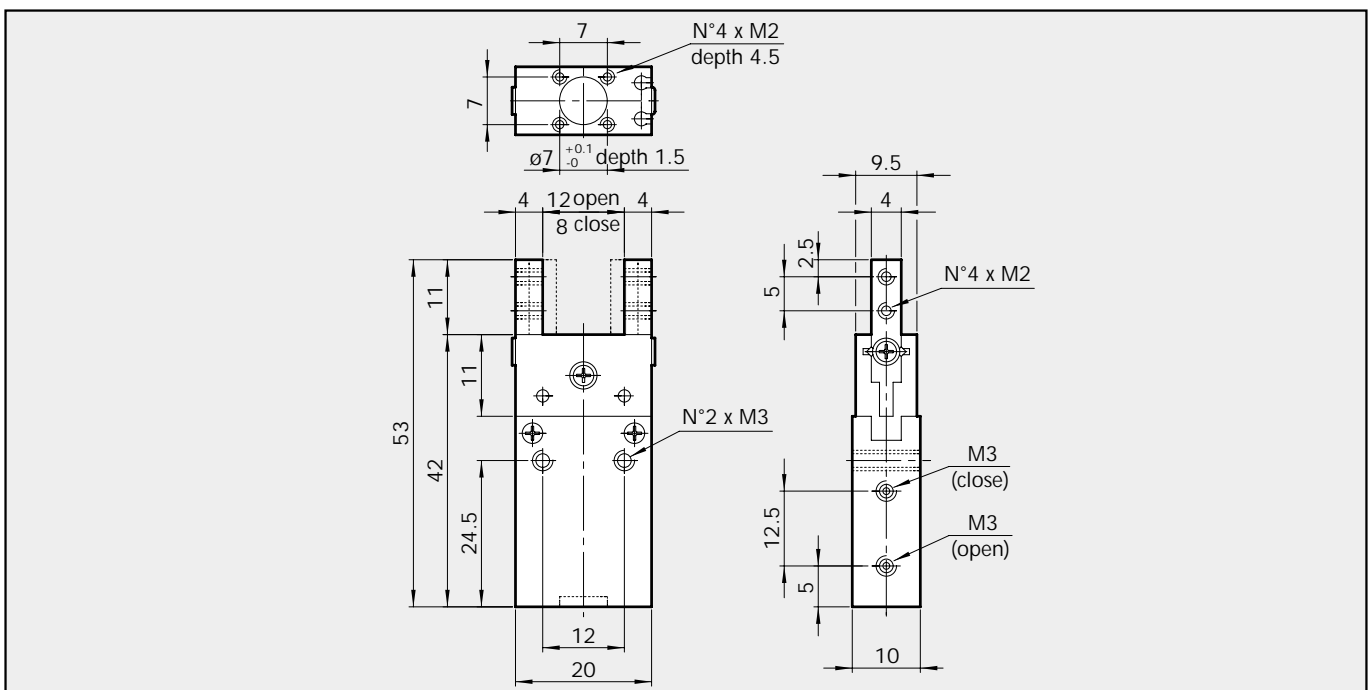

ORDERING CODES

Code	Description
W157006200	GRIPPER WITH 2 PARALLEL JAWS P2-6 (For sensor see W0950044180 page 1/23)

DIMENSIONS

PNEUMATIC GRIPPER WITH 2 PARALLEL ROLLER-RECIRCULATION JAWS - SERIES P2 - 10

1

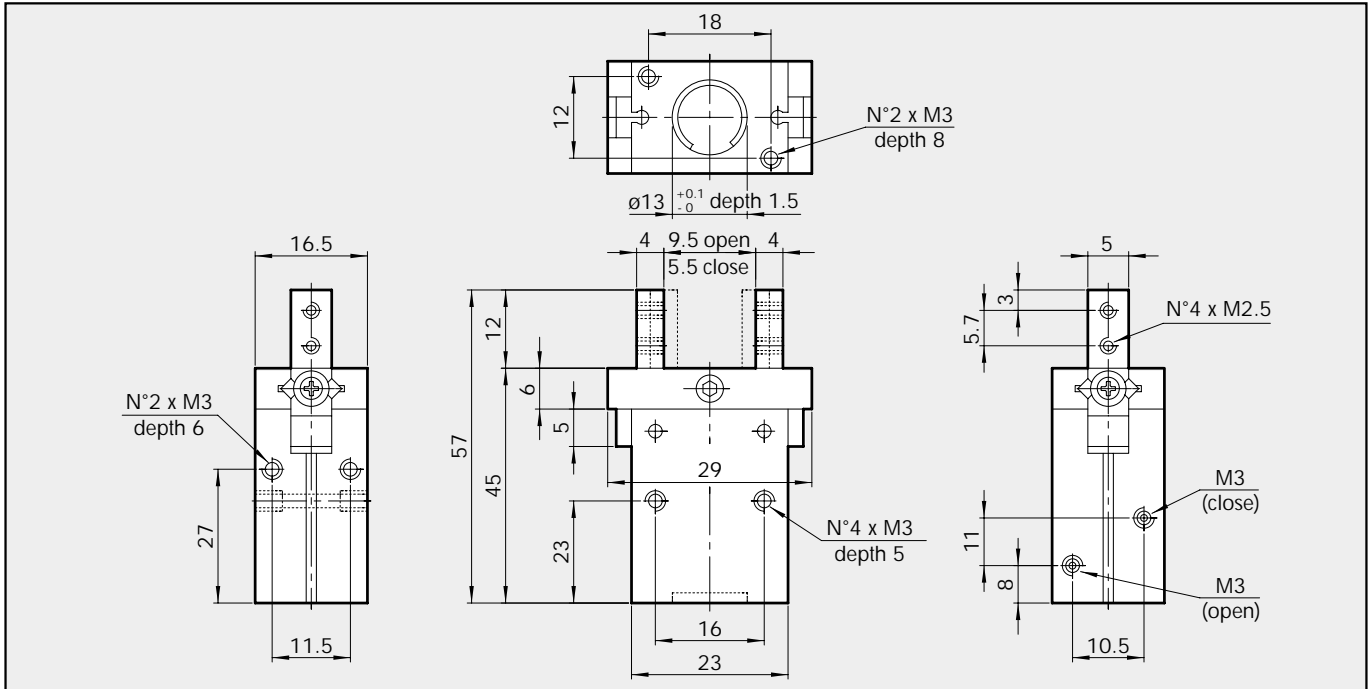

ORDERING CODES

Code	Description
W1570100200	GRIPPER WITH 2 PARALLEL JAWS P2-10 (For sensor see W0950044180 page 1/23)

PNEUMATIC GRIPPER WITH 2 PARALLEL ROLLER-RECIRCULATION JAWS - SERIES P2 - 16

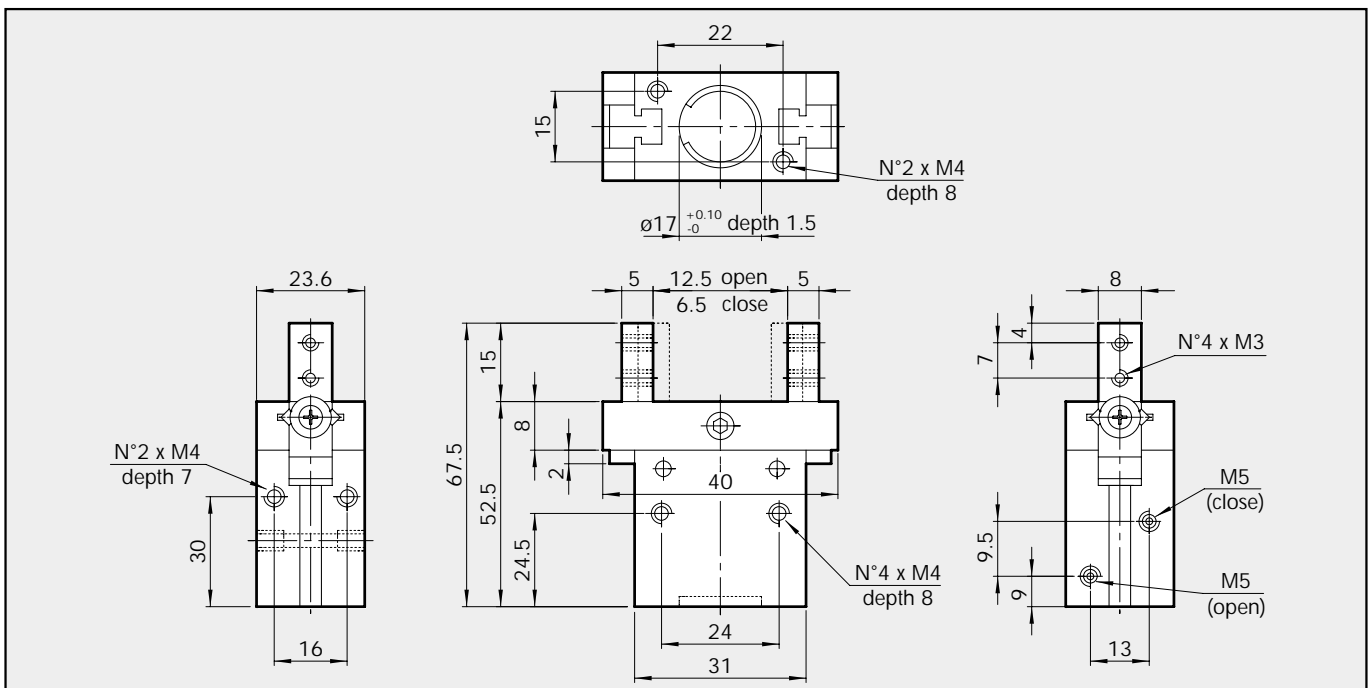

ORDERING CODES

Code	Description
W1570160200	GRIPPER WITH 2 PARALLEL JAWS P2-16 (For sensor see W0950025390 and following, page 1/23)

PNEUMATIC GRIPPER WITH 2 PARALLEL ROLLER-RECIRCULATION JAWS – SERIES P2 - 20

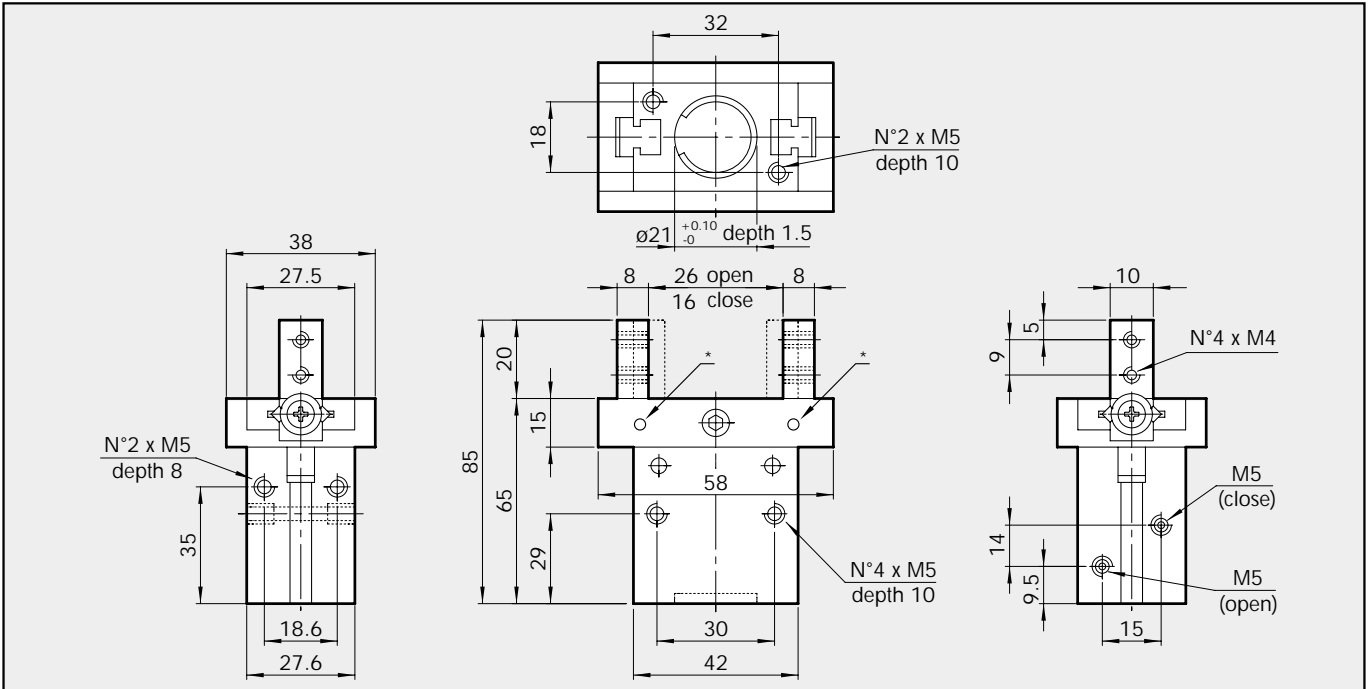

ORDERING CODES

Code	Description
W1570200200	GRIPPER WITH 2 PARALLEL JAWS P2-20 (For sensor see W0950025390 and following, page 1/23)

* Pins for backlash adjustment

PNEUMATIC GRIPPER WITH 2 PARALLEL ROLLER-RECIRCULATION JAWS – SERIES P2 - 25

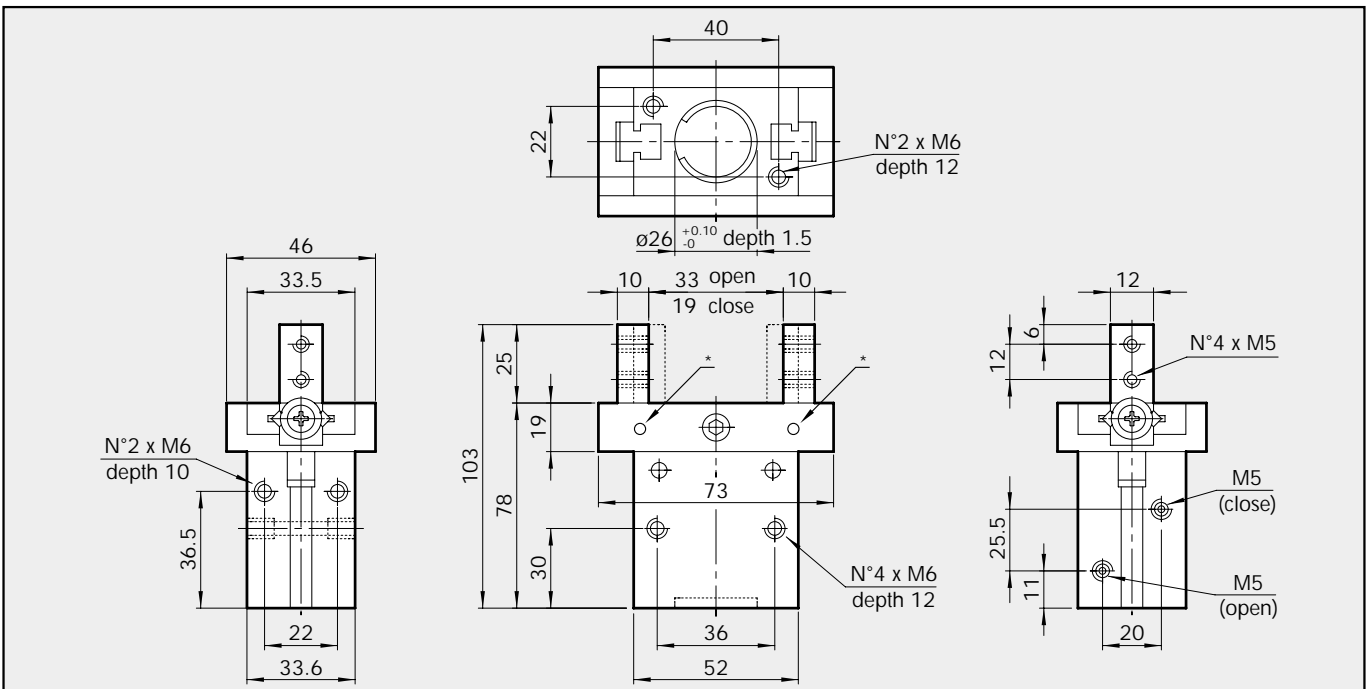

ORDERING CODES

Code	Description
W1570250200	GRIPPER WITH 2 PARALLEL JAWS P2-25 (For sensor see W0950025390 and following, page 1/23)

* Pins for backlash adjustment